

# Block 08 — Two-terminal theory and transforms

## Student Group

First Name	Surname	Matrikel Nr.

## Table of Contents

- Block 08 — Two-terminal theory and transforms** ..... 3
- 8.0 Intro** ..... 4
  - 8.0.1 Learning Objectives ..... 4
  - 8.0.2 Preparation at Home ..... 4
  - 8.0.3 90-minute plan ..... 4
  - 8.0.4 Conceptual Overview ..... 5
- 8.1 Core content** ..... 5
  - 8.1.1 Two-Terminal Theory / One-Port Theory ..... 5
    - Hint: ..... 7
  - 8.1.2 Superposition Principle ..... 7
    - Example 1 - from an interview of a consulting company ..... 7
    - Example 2 - Spring Force and Displacement ..... 7
    - Notice: ..... 8
    - Example ..... 9
- 8.2 Common Pitfalls** ..... 10
- 8.3 Exercises** ..... 10
  - Longer Exercises ..... 10
    - Exercise E4.5.1 Converting a bipolar signal to a unipolar signal (HARD, not from written test) ..... 11
      - Circuit 1 : only consider  $U_{\text{S}}$ , ignore  $U_{\text{I}}$  ..... 11
      - Circuit 2 : only consider  $U_{\text{I}}$ , ignore  $U_{\text{S}}$  ..... 12
      - Superposition: Let's sum it up! ..... 13
      - Situation I :  $U_{\text{I,min}} = -15 \text{ ~}\text{V}$  shall create  $U_{\text{O,min}} = 0 \text{ ~}\text{V}$  ..... 14
      - Situation II :  $U_{\text{I,max}} = +15 \text{ ~}\text{V}$  shall create  $U_{\text{O,max}} = 3.3 \text{ ~}\text{V}$  ..... 14
    - Aufgabe 4.5.2: open circuit voltage via superposition (exam task, approx. 12 % of a 60-minute exam, WS2020) ..... 15

---

Exercise 4.5.3 -Variation: open circuit voltage via superposition (exam task, approx. 12 % of a 60-minute exam, WS2020) .....	18
Exercise 4.5.4 - Variation: open circuit voltage via superposition (exam task, approx. 12 % of a 60-minute exam, WS2020) .....	20
<b>Embedded resources</b> .....	20

# Block 08 — Two-terminal theory and transforms

Fig. 1: examples for networks

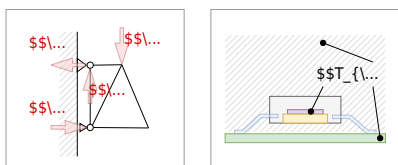

Network analysis plays a central role in electrical engineering. It is so important because it can be used to simplify what at first sight appear to be complicated circuits and systems to such an extent that they can be understood and results derived from them.

In addition, networks also occur in other areas, for example, the momentum flux through a truss or the heat flux through individual hardware elements ([figure 1](#), or [an example for heat flow through electronics](#) ). The concepts shown below can also be applied to these networks.

On the [wiki page for network analysis](#) the different methods are described very well in a compact way

## 8.0 Intro

### 8.0.1 Learning Objectives

- Define **terminal** and **port**; distinguish **one-port** (two-terminal) vs. **two-port** views; identify input/output variables  $(U, I)$  at a port.
- Apply **source transformations** between a voltage source with series  $R$  and a current source with parallel  $R$  using  $U_0 = I_0 R$ ; state validity conditions (linear, bilateral, time-invariant networks).
- Construct **Thevenin** and **Norton** equivalents seen at a port: find  $U_{\text{oc}}$ ,  $I_{\text{sc}}$ , and  $R_{\text{Th}} = R_{\text{N}}$  by deactivating sources; relate  $U_{\text{Th}} = U_{\text{oc}}$ ,  $R_{\text{Th}} = R_{\text{N}}$ ,  $I_{\text{No}} = I_{\text{sc}}$ .
- Use the **superposition principle** to compute branch currents/voltages in multi-source linear networks; outline the deactivate–solve–sum workflow.
- Combine transforms to reduce complex resistive networks to an **unloaded / loaded divider** and to size  $R_{\text{L}}$  for given performance goals (tie-in to Block 07 figures).

### 8.0.2 Preparation at Home

And again:

- Please read through the following chapter.
- Also here, there are some clips for more clarification under 'Embedded resources'.

For checking your understanding please do the following exercise:

- 4.5.3

### 8.0.3 90-minute plan

1. Warm-up (8 min):
  1. Quick quiz on passive/active sign convention and  $P = U \cdot I$  (from Block 07).
  2. Identify ports and choose measurement directions on 2–3 small circuits.
2. Core concepts & derivations (58 min):
  1. (1) **Source transformations** ( $U_0 \rightarrow I_0$ , shared  $R$ ), permissible assumptions, and fast checks (10 min).
  2. (2) **Thevenin/Norton construction** at a chosen port:  $U_{\text{oc}}$ ,  $I_{\text{sc}}$ ,  $R_{\text{Th}} = R_{\text{N}}$  (18 min).
  3. (3) **Superposition method**: deactivate sources, compute partial results, sum; worked DC example (15 min).
3. Practice (20 min):
  1. Pair exercise set: reduce a 3-source network to Thevenin, then find  $U_{\text{L}}$ ,  $I_{\text{L}}$ .
4. Wrap-up (5 min):
  1. Summary table (when to use which method); minute paper: “One thing I can now do, one

question I still have.”

## 8.0.4 Conceptual Overview

1. **Port thinking:** Draw a virtual cut around the “rest of the world”. At that boundary (two terminals), everything inside looks like an equivalent **linear source** (Thevenin/Norton) to everything outside.
2. **Source transformations:** A series source  $(U_0, R)$  is equivalent to a parallel source  $(I_0, R)$  if  $U_0 = I_0 R$ . Use them to simplify ladders and to expose a clean port.
3. **Thevenin/Norton from measurements:**
  1. Open-circuit the load  $\rightarrow$  measure/compute  $U_{\text{oc}} = U_{\text{Th}}$ .
  2. Short the load (only if safe/valid)  $\rightarrow I_{\text{sc}} = I_{\text{No}}$ .
  3. Deactivate sources  $\rightarrow$  compute the internal resistance  $R_{\text{i}} = R_{\text{Th}} = R_{\text{No}}$ .
4. **Superposition (linear networks only):** Voltages and currents **add**; powers do **not**. For each source: deactivate the others (ideal  $U$ -sources  $\rightarrow$  short; ideal  $I$ -sources  $\rightarrow$  open), solve the partial, then sum with signs.
5. **Choosing a method:** Use source transforms for quick topology changes, Thevenin/Norton to isolate a load, and superposition when multiple sources block easy reduction.

## 8.1 Core content

### 8.1.1 Two-Terminal Theory / One-Port Theory

Fig. 1: examples for networks

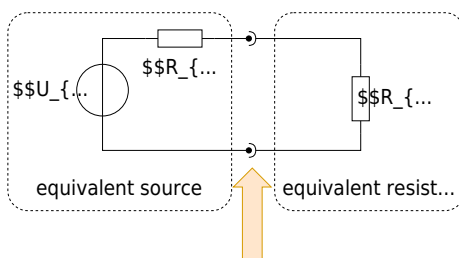

In order to understand the two-terminal theory / one-port theory, we first have to understand what a Terminal and port is.

So, have a look to [figure 1](#):

1. A terminal or pole is simply an (imaginary or real) connector. This is shown in the diagram by a filled circle on one wire, plus a semicircle on the other wire
2. A port is given by two terminals

But, how could this help us in simplifying circuits?

Well: Usually, the voltage over or the current into one component or a group of component has to be found.

Now, it is practical, that

- you can substitute every passive linear part (= consisting only of resistors) by a single equivalent resistor.
- you can substitute every active linear part (= consisting of resistors and sources) by a single equivalent linear source.

A linear part is here a circuit consisting of linear components. In general, ohmic resistors, sources, capacitors and inductors are linear - here, we only look onto resistors. (non-linear are most of the semiconductor components, like diodes).

So, what can we do? Once you search for a distinct voltage or current:

1. Imagine a virtual cut around this part. You get a passive linear part and a active linear part.
2. Calculate the single equivalent resistor and single equivalent linear source. You get an unloaded voltage divider.
3. Calculate the voltage divider

Voilà, we have a way to find our desired voltage or current in a complicated circuitry.

**Hint:**

There is a trick to get the internal resistance of the source easily, so without continuous back-and-forth between linear voltage source and linear current source:

When one is only interested in the resistance of a complex circuit, do as follows:

1. substitute every ideal source with its internal resistance (ideal voltage source → short circuit, ideal current source → unconnected).
2. calculate the equivalent resistance by means of series and parallel sub-circuits.

### 8.1.2 Superposition Principle

The superposition principle shall first be illustrated by some examples:

**Example 1 - from an interview of a consulting company**

**Task:** Three students are to fill a pool. If Alice has to fill it alone, she would need 2 days. Bob would need 3 days and Carol would need 4 days. How long would it take all three to fill a pool if they helped together?

The question sounds far off-topic at first but is directly related. The point is that to solve it, filling the pool is assumed to be linear. So Alice will fill  $\frac{1}{2}$ , Bob  $\frac{1}{3}$ , and Carol  $\frac{1}{4}$  of the pool per day. So on the first day,  $\frac{1}{2} + \frac{1}{3} + \frac{1}{4} = \frac{6 + 4 + 3}{12} = \frac{13}{12}$  of the pool filled. So the three of them need  $\frac{12}{13}$  of a day.

However, this solution path is only possible because in linear systems the partial results can be added.

**Example 2 - Spring Force and Displacement**

Fig. 3: mechanical spring

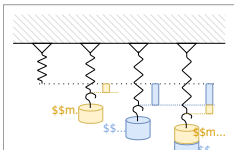

**Task:** A mechanical, linear spring is displaced due to masses  $m_1$  and  $m_2$  in the Earth's gravitational field (see [figure 3](#)). What is the magnitude of the deflection if both masses are attached simultaneously?

Again, a linear law is used here: 
$$\vec{s} = f(\vec{F}) = -D \cdot \vec{F}$$

The (seemingly trivial) approach applies here: 
$$\vec{s}_{1+2} = f(\vec{F}_1 + \vec{F}_2) = -D \cdot (\vec{F}_1 + \vec{F}_2) = -D \cdot \vec{F}_1 - D \cdot \vec{F}_2 = f(\vec{F}_1) + f(\vec{F}_2) = \vec{s}_1 + \vec{s}_2$$

### Notice:

In a physical system in which effect and cause are linearly related, the effect of each cause can first be determined separately. The total effect is then the sum of the individual effects.

For electrical engineering this principle was described by [Hermann von Helmholtz](#):

The currents in the branches of a linear network are equal to the sum of the partial currents in the branches concerned caused by the individual sources.

Thus, in the superposition method, the current (or voltage) sought in a circuit with multiple sources can be viewed as a superposition of the resulting currents (or voltages) of the individual sources. Simple view of the superposition principle

The “recipe” for the overlay is as follows:

1. Choose the next source  $x$
2. Replace all ideal sources with their respective equivalent resistors:

1. ideal voltage sources by short circuits
2. ideal current sources by an open line
3. Calculate the partial currents sought in the branches considered.
4. Go to the next source  $x=x+1$  <sup>1)</sup>, and to point 2, as long as the partial currents of all sources have not been calculated.
5. Add up the partial currents in the branches under consideration, observing the correct sign.

This procedure is explained again in more detail using examples in the two videos on the right.

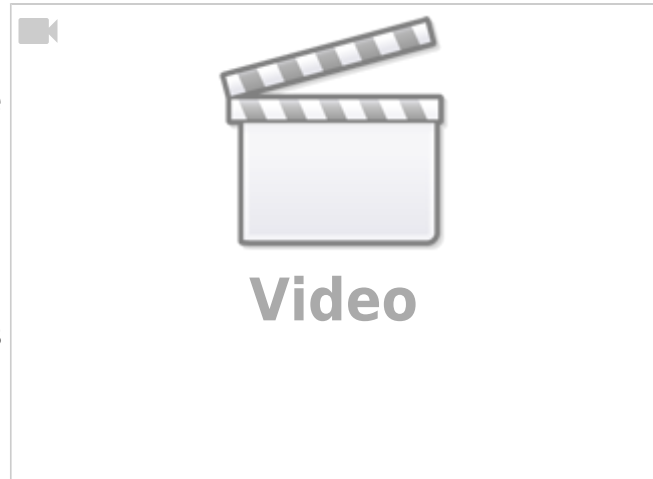

A more complex example of the superposition method

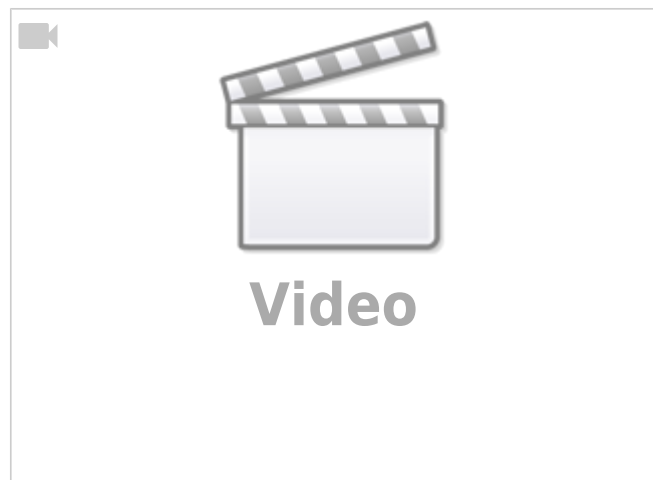

## Example

Fig. 4: example circuit with superposition

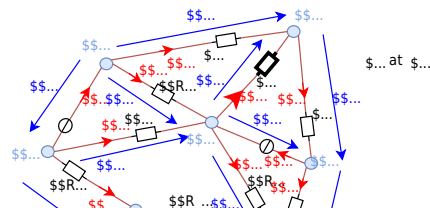

## 8.2 Common Pitfalls

- **Deactivating sources incorrectly:** replacing an ideal voltage source with an **open** (instead of a short), or an ideal current source with a **short** (instead of an open).
- **Superposing powers:** only  **$P_u$**  and  **$P_i$**  superpose;  **$P_P$**  does not. Compute powers **after** summing.
- **Illegal short/open tests:** shorting across an element that cannot be shorted (e.g., an ideal current source without care) or opening where it breaks circuit definitions.
- **Sign/arrow mismatches:** mixing passive/active sign conventions leads to wrong partial signs in superposition.
- **Applying linear methods to non-linear/time-varying parts:** Thevenin/Norton and superposition require **linearity** (and usually bilateral behavior).
- **Ignoring loading:** using the unloaded divider ratio  $\frac{R_2}{R_1+R_2}$  while a finite  $R_L$  is attached  $\rightarrow$  systematic voltage error.

## 8.3 Exercises

### Longer Exercises



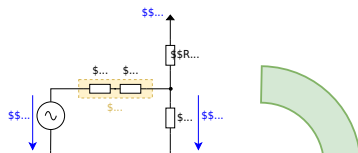

$$\begin{aligned}
 U_{\text{O}}^{(1)} &= U_{\text{S}} \cdot \frac{R_2 \parallel R_4}{R_1 + R_2 \parallel R_4} = U_{\text{S}} \cdot \frac{\frac{R_2 R_4}{R_2 + R_4}}{R_1 + \frac{R_2 R_4}{R_2 + R_4}} \\
 &= U_{\text{S}} \cdot \frac{R_2 R_4}{(R_2 + R_4) + R_2 R_4} = U_{\text{S}} \cdot \frac{R_2 R_4}{R_1 R_2 + R_1 R_4 + R_2 R_4}
 \end{aligned}$$

**Circuit 2 : only consider  $U_{\text{I}}$ , ignore  $U_{\text{S}}$**

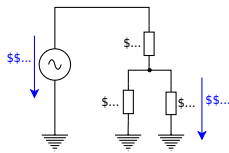

$$\begin{aligned} U_{\text{O}}^{(2)} &= U_{\text{I}} \cdot \frac{\{R_1 || R_2\}}{R_4 + R_1 || R_2} = U_{\text{I}} \cdot \frac{\left\{ \frac{\{R_1 R_2\}}{R_1 + R_2} \right\}}{R_4 + \left\{ \frac{\{R_1 R_2\}}{R_1 + R_2} \right\}} \\ &= U_{\text{I}} \cdot \frac{\{R_1 R_2\}}{R_4 R_1 + R_4 R_2 + R_1 R_2} \end{aligned}$$

### Superposition: Let's sum it up!

These two intermediate voltages for the single sources have to be summed up as  $U_{\text{O}} = U_{\text{O}}^{(1)} + U_{\text{O}}^{(2)}$ .

When deeper investigated, one can see that the denominator for both  $U_{\text{O}}^{(1)}$  and  $U_{\text{O}}^{(2)}$  is the same.

We can also simplify further when looking at often-used sub-terms (here:  $R_2$ )

$$\begin{aligned} U_{\text{O}} &= \left\{ \frac{1}{R_4 R_1 + R_4 R_2 + R_1 R_2} \right\} \\ &\cdot (U_{\text{S}} \cdot R_2 R_4 + U_{\text{I}} \cdot R_1 R_2) \parallel U_{\text{O}} \cdot (R_4 R_1 + R_4 R_2 + R_1 R_2) \\ &= U_{\text{S}} \cdot R_2 R_4 + U_{\text{I}} \cdot R_1 R_2 \parallel U_{\text{O}} \cdot \left( \frac{\{R_1 R_4\}}{R_2} + R_4 + R_1 \right) \\ &= U_{\text{S}} \cdot R_4 + U_{\text{I}} \cdot R_1 \end{aligned}$$

The formula (1) is the general formula to calculate the output voltage  $U_{\text{O}}$  for a changing input voltage  $U_{\text{I}}$ , where the supply voltage  $U_{\text{S}}$  is constant.

Now, we can use the requested boundaries:

1. For the minimum input voltage  $U_{\text{I}} = -15 \text{ V}$ , the output voltage shall be  $U_{\text{O}} = 0 \text{ V}$
2. For the maximum input voltage  $U_{\text{I}} = +15 \text{ V}$ , the output voltage shall be  $U_{\text{O}} = 3.3 \text{ V}$

This leads to two situations:

**Situation I :  $U_{\text{I,min}} = -15 \text{ V}$  shall create  $U_{\text{O,min}} = 0 \text{ V}$**

We put  $U_{\text{A}} = 0 \text{ V}$  in the formula (1) : 
$$0 = U_{\text{S}} \cdot R_4 + U_{\text{I,min}} \cdot R_1 - U_{\text{I,min}} \cdot R_1 + U_{\text{S}} \cdot R_4 \cdot \frac{R_1}{R_4} = -\frac{U_{\text{S}}}{U_{\text{I,min}}} = k_{14} \tag{2}$$

So, with formula (2), we already have a relation between  $R_1$  and  $R_4$ .  
Yeah  $\square$

The next step is situation 2

**Situation II :  $U_{\text{I,max}} = +15 \text{ V}$  shall create  $U_{\text{O,max}} = 3.3 \text{ V}$**

We use formula (2) to substitute  $R_1 = k_{14} \cdot R_4$  in formula (1), and: 
$$U_{\text{O,max}} \cdot (k_{14} \cdot \frac{R_4^2}{R_2} + R_4 + k_{14} \cdot R_4) = U_{\text{S}} \cdot R_4 + U_{\text{I,max}} \cdot k_{14} \cdot R_4 \cdot \frac{R_4}{R_2} + U_{\text{O,max}} \cdot (k_{14} \cdot \frac{R_4}{R_2} + 1 + k_{14}) = U_{\text{S}} + U_{\text{I,max}} \cdot k_{14} \cdot \frac{R_4}{R_2} + 1 + k_{14} = \frac{U_{\text{S}} + U_{\text{I,max}} \cdot k_{14}}{U_{\text{O,max}}} \cdot \frac{R_4}{R_2} = \frac{U_{\text{S}} + U_{\text{I,max}} \cdot k_{14}}{U_{\text{O,max}}} \cdot \frac{R_4}{R_2} - (1 + k_{14}) \cdot \frac{R_4}{R_2} = \frac{U_{\text{S}} + U_{\text{I,max}} \cdot k_{14}}{k_{14} \cdot U_{\text{O,max}}} - \frac{1 + k_{14}}{k_{14}} \tag{3}$$

So, another relation for  $R_4$  and  $R_2$ .  $\square$

So, to get values for the relations, we have to put in the values for the input and output voltage conditions. For  $k_{14}$  we get by formula (2): 
$$k_{14} = \frac{R_1}{R_4} = -\frac{5 \text{ V}}{-15 \text{ V}} = \frac{1}{3}$$

This value  $k_{14}$  we can use for formula (3): 
$$\frac{R_4}{R_2} = \frac{U_{\text{S}} + U_{\text{I,max}} \cdot k_{14}}{k_{14} \cdot U_{\text{O,max}}} - \frac{1 + k_{14}}{k_{14}}$$

$$\frac{1}{R_2} = \frac{5 \text{ V} + 15 \text{ V} \cdot \left\{ \frac{1}{3} \right\}}{3.3 \text{ V} \cdot \left\{ \frac{1}{3} \right\}} - \left\{ 1 + \left\{ \frac{1}{3} \right\} \right\} \frac{1}{\left\{ \frac{1}{3} \right\}} \quad \& \approx 5.09$$

We could now - theoretically - arbitrarily choose one of the resistors, e.g.,  $R_2$ , and then calculate the other two.

But we must consider another boundary, a boundary for  $R_S$ . The maximum voltage and the maximum current are given for the sensor. By this, we can calculate  $R_S$ :

$$R_S = \frac{U_{\text{OC}}}{I_{\text{SC}}} = \frac{U_{\text{S,max}}}{I_{\text{S,max}}} = \frac{15 \text{ V}}{1 \text{ mA}} = 15 \text{ k}\Omega$$

Therefore,  $R_4 = R_S + R_3$  must be larger than this.

#### Aufgabe 4.5.2: open circuit voltage via superposition (exam task, approx. 12 % of a 60-minute exam, WS2020)

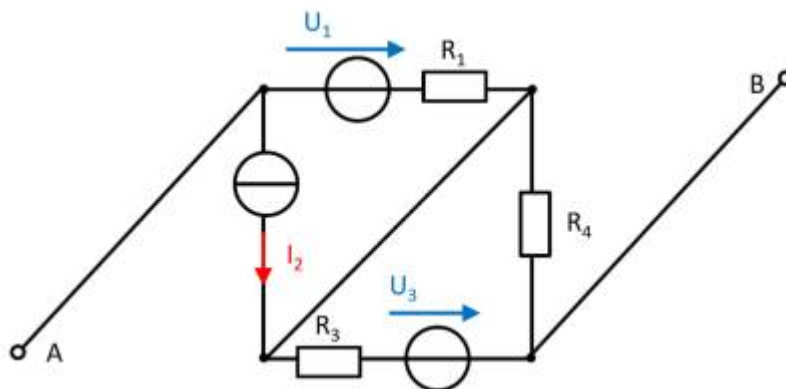

A circuit is given with the following parameters

$$R_1 = 5 \text{ }\Omega$$

$$U_1 = 2 \text{ V}$$

$$I_2 = 1 \text{ A}$$

$$R_3 = 20 \text{ }\Omega$$

$$U_3 = 8 \text{ V}$$

$$R_4 = 10 \text{ }\Omega$$

Determine the open circuit voltage between A and B using the principle of superposition.

Tips

- What do the individual circuits look like, by which the effects of the individual sources can be calculated?  
Which equivalent resistor must be used to replace a current or voltage source when calculating the individual effects?
- Where are the open-circuit voltages applied when looking at the individual

components?

Solution

First, the individual circuits must be created, from which the effect of the individual sources between points A and B can be determined.

**(Voltage) source  $U_1$**

- substitute the current source  $I_2$  with a short-circuit
- substitute the voltage source  $U_3$  with an open circuit

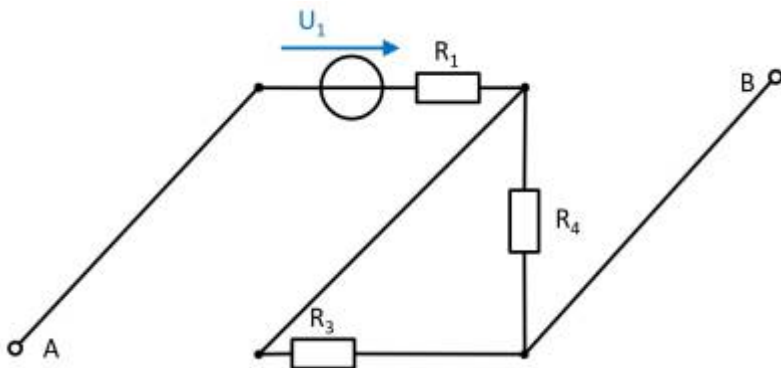

The components can be moved in order to understand the circuit s bit better.

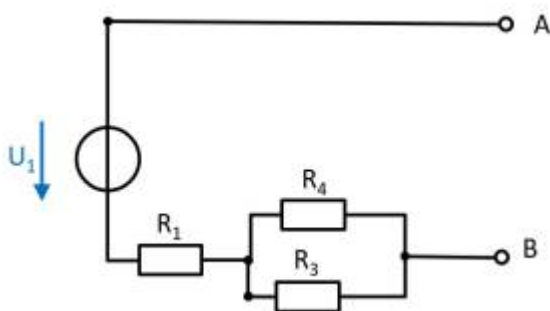

For the open circuit, no current is flowing through any resistor. Therefore, the effect is:  
 $U_{AB,1} = U_1$

**(current) source  $I_2$**

- substitute the voltage source  $U_1$  with an open circuit
- substitute the voltage source  $U_3$  with an open circuit

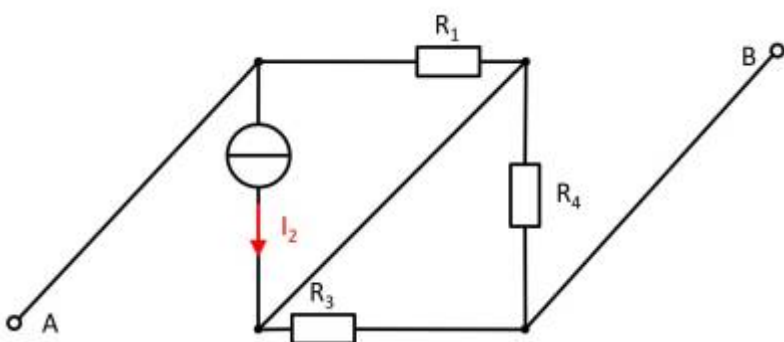

Also here, the components can be shifted for a better understanding:

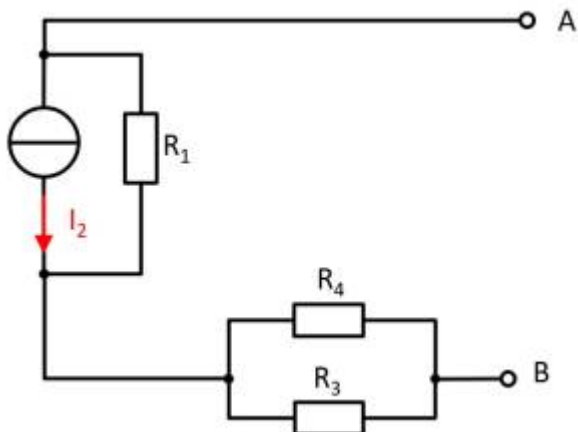

Here, the current source  $I_2$  creates a voltage drop  $U_{AB,2}$  on the resistor  $R_2$  :  
 $U_{AB,2} = - R_2 \cdot I_2$

**(Voltage) source  $U_3$**

- substitute the voltage source  $U_1$  with an open circuit
- substitute the current source  $I_2$  with a short-circuit

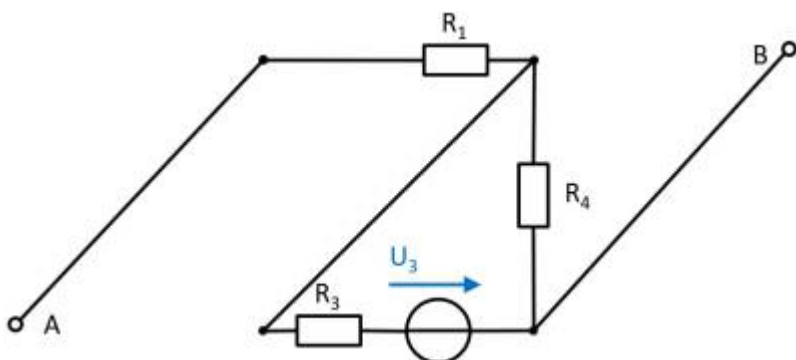

Again, rearranging the circuit might help for an understanding:

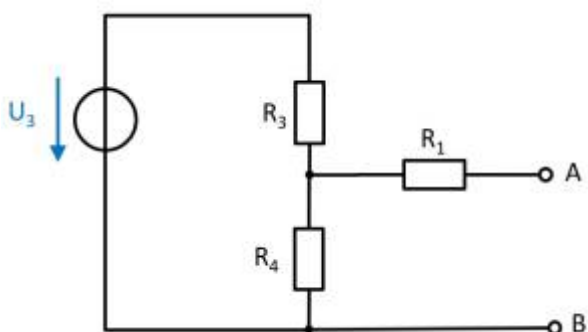

In this case, between the unloaded outputs  $A$  and  $B$  there will be an unloaded voltage divider given by  $R_3$  and  $R_4$ . On  $R_1$  there is no voltage drop since there is no current flow out of the unloaded outputs.

Therefore:

$$U_{AB,3} = \frac{R_4}{R_3 + R_4} \cdot U_3$$

**resulting voltage**

$$U_{\text{AB}} = U_1 - R_1 \cdot I_2 + \frac{R_4}{R_3 + R_4} \cdot U_3$$

Final value

$$U_{\text{AB}} = 2 \text{ V} - 5 \Omega \cdot 1 \text{ A} + \frac{10 \Omega}{20 \Omega + 10 \Omega} \cdot 8 \text{ V} \\ \rightarrow U_{\text{AB}} = -0.333 \text{ V}$$

**Exercise 4.5.3 -Variation: open circuit voltage via superposition (exam task, approx. 12 % of a 60-minute exam, WS2020)**

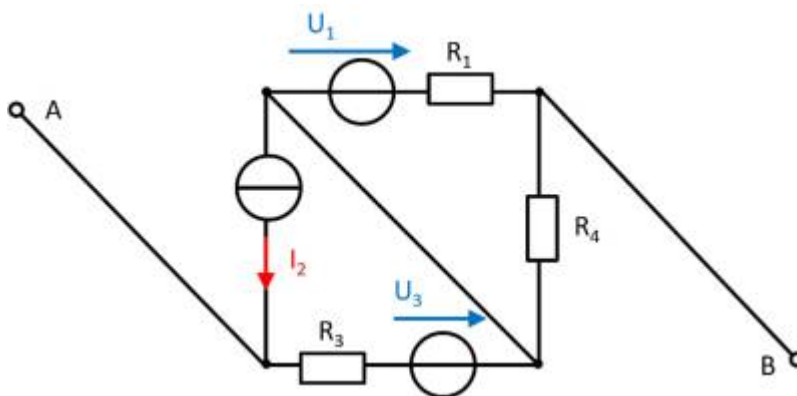

A circuit is given with the following parameters

$$R_1 = 5 \Omega$$

$$U_1 = 2 \text{ V}$$

$$I_2 = 1 \text{ A}$$

$$R_3 = 20 \Omega$$

$$U_3 = 8 \text{ V}$$

$$R_4 = 10 \Omega$$

Determine the open circuit voltage between A and B using the principle of superposition.

Solution

Case 1: For this case is  $I_2 = 0 \text{ A}$  and  $U_3 = 0 \text{ V}$ . The voltage is at  $R_4$ .

$$U_{\text{AB},1} = \frac{R_4}{R_1 + R_4} U_1 = \frac{10\ \Omega}{5\ \Omega + 10\ \Omega} \cdot 2\ \text{V} = 1.33\ \text{V}$$
 Case 2: For this case is  $U_1 = 0\ \text{V}$  and  $U_3 = 0\ \text{V}$ . The voltage is at  $R_3$ .

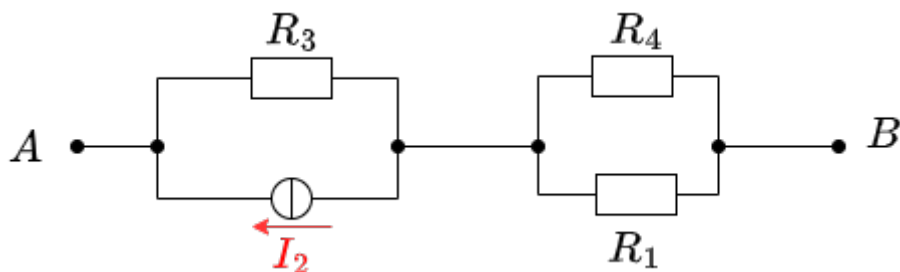

$$U_{\text{AB},2} = R_3 I_2 = 20\ \Omega \cdot 1\ \text{A} = 20\ \text{V}$$
 Case 3: For this case is  $U_1 = 0\ \text{V}$  and  $I_2 = 0\ \text{A}$ . The voltage comes from the source  $U_3$ .

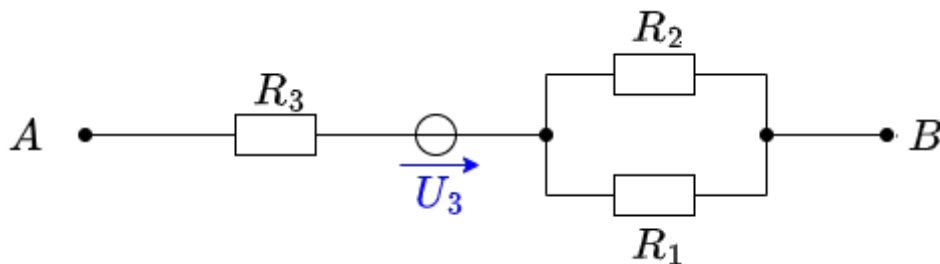

$U_{\text{AB},3} = 8 \text{ V}$  Superposition means adding the voltages of all three cases.  
 $U_{\text{AB}} = U_{\text{AB},1} + U_{\text{AB},2} + U_{\text{AB},3} = 1.33 \text{ V} + 20 \text{ V} + 8 \text{ V}$

Final value

$U_{\text{AB}} = 29.333... \text{ V} \rightarrow 29.3 \text{ V}$

**Exercise 4.5.4 - Variation: open circuit voltage via superposition (exam task, approx. 12 % of a 60-minute exam, WS2020)**

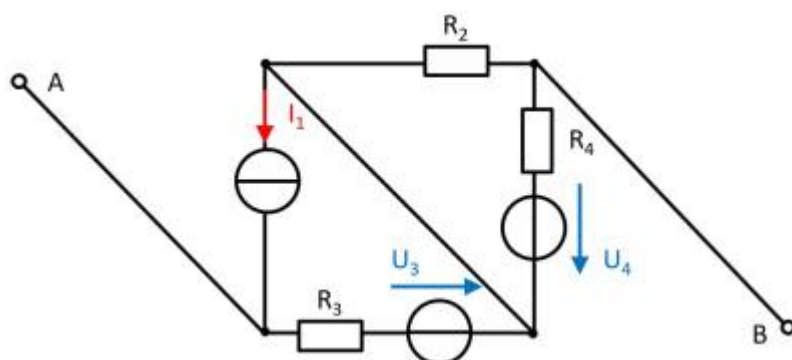

A circuit is given with the following parameters

- $I_1 = 2 \text{ A}$
- $R_2 = 5 \text{ }\Omega$
- $R_3 = 20 \text{ }\Omega$
- $U_3 = 1 \text{ V}$
- $R_4 = 10 \text{ }\Omega$
- $U_4 = 3 \text{ V}$

Determine the open circuit voltage between A and B using the principle of superposition.

**Embedded resources**

Introduction to Superposition Method (starting from 34:24, Befor there are other methods not covered here)

1)  
 $x=x+1$  is not meant mathematically, but procedurally as in the programming language C

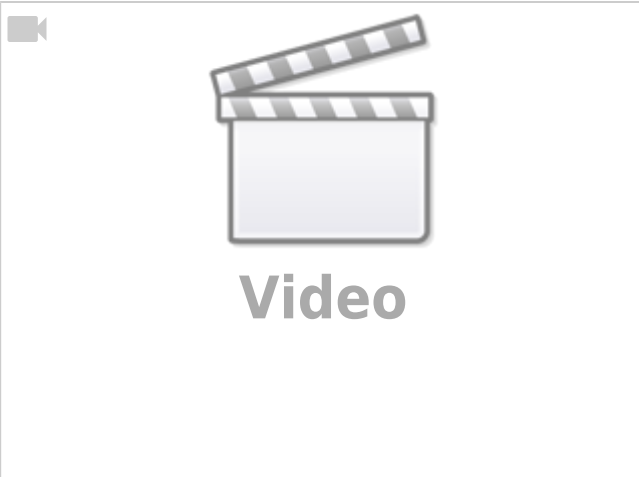

From:  
<https://first.mexle.te.hs-heilbronn.de/> - **MEXLE Wiki**

Permanent link:  
[https://first.mexle.te.hs-heilbronn.de/electrical\\_engineering\\_and\\_electronics\\_1/block08](https://first.mexle.te.hs-heilbronn.de/electrical_engineering_and_electronics_1/block08)

Last update: **2026/01/10 13:02**

