

# Exam Winter Semester 2022

## Student Group

First Name	Surname	Matrikel Nr.

## Table of Contents

- Exercise E1 Resistance of a Wire by Resistivity (written test, approx. 6 % of a 60-minute written test, WS2022) ..... 3
- Exercise E1 Resistance of a Wire by Resistivity (written test, approx. 6 % of a 60-minute written test, WS2022) ..... 3
- Exercise E2 Temperature-dependent Resistance (written test, approx. 6 % of a 60-minute written test, WS2022) ..... 4
- Exercise E2 Temperature-dependent Resistance (written test, approx. 6 % of a 60-minute written test, WS2022) ..... 4
- Exercise E3 Pure Resistor Network Simplification (written test, approx. 13 % of a 60-minute written test, WS2022) ..... 5
- Exercise E4 Pure Resistor Network Simplification (written test, approx. 13 % of a 60-minute written test, WS2022) ..... 6
- Exercise E5 Equivalent linear Source (written test, approx. 14 % of a 60-minute written test, WS2022) ..... 8
- Exercise E6 Equivalent linear Source (written test, approx. 14 % of a 60-minute written test, WS2022) ..... 12
- Exercise E7 Charging Capacitors (written test, approx. 16 % of a 60-minute written test, WS2022) ..... 16
- Exercise E8 Charging Capacitors (written test, approx. 16 % of a 60-minute written test, WS2022) ..... 17
- Exercise E9 Analyzing complex Impedances (written test, approx. 14 % of a 60-minute written test, WS2022) ..... 19
- Exercise E10 Analyzing complex Impedances (written test, approx. 14 % of a 60-minute written test, WS2022) ..... 19
- Exercise E11 Impedances at different Frequencies (written test, approx. 18 % of a 60-minute written test, WS2022) ..... 20
- Exercise E12 Impedances at different Frequencies (written test, approx. 18 % of a 60-minute written test, WS2022) ..... 20
- Exercise E13 Complex Impedance Circuit (written test, approx. 15 % of a 60-minute written test, WS2022) ..... 20

---

test, WS2022) .....	21
Exercise E14 Complex Impedance Circuit (written test, approx. 15 % of a 60-minute written test, WS2022) .....	24

G

**Exercise E1 Resistance of a Wire by Resistivity**  
**(written test, approx. 6 % of a 60-minute written test, WS2022)**

A heating element made of nichrome wire with a temperature coefficient of  $1.80 \times 10^{-5} \text{ } ^\circ\text{C}^{-1}$  is used. Electric power dissipation (= heat flow) of  $P=40 \text{ W}$  is necessary. Determine the current  $I$  needed to operate it. for heating elements. The Nichrome wire has a resistivity of  $1.10 \cdot 10^{-6} \text{ } \Omega \text{ m}$ . The heating element is  $3 \text{ m}$  long and has a diameter of  $3.57 \text{ mm}$ .  
 Solution:  $R = 10^{-3} \text{ } \Omega$

Solution

$$\begin{aligned} P &= U \cdot I = R \cdot I^2 \quad \rightarrow \quad I = \sqrt{\frac{P}{R}} = \sqrt{\frac{40 \text{ W}}{0.33 \text{ } \Omega}} \end{aligned}$$

$$\begin{aligned} R &= \rho \cdot \frac{l}{A} \quad | \quad \text{with } A = r^2 \cdot \pi = \frac{1}{4} d^2 \cdot \pi \quad || \quad R = \rho \cdot \frac{4 \cdot l}{d^2 \cdot \pi} \quad || \quad R = 1.10 \cdot 10^{-6} \text{ } \Omega \text{ m} \cdot \frac{4 \cdot 3 \text{ m}}{(3.57 \cdot 10^{-3} \text{ m})^2 \cdot \pi} \end{aligned}$$

**Exercise E1 Resistance of a Wire by Resistivity**  
**(written test, approx. 6 % of a 60-minute written test, WS2022)**

A heating element made of nichrome wire with a temperature coefficient of  $1.80 \times 10^{-5} \text{ } ^\circ\text{C}^{-1}$  is used. Electric power dissipation (= heat flow) of  $P=40 \text{ W}$  is necessary. Determine the current  $I$  needed to operate it. for heating elements. The Nichrome wire has a resistivity of  $1.10 \cdot 10^{-6} \text{ } \Omega \text{ m}$ . The heating element is  $3 \text{ m}$  long and has a diameter of  $3.57 \text{ mm}$ .  
 Solution:  $R = 10^{-3} \text{ } \Omega$

Solution

$$\begin{aligned} P &= U \cdot I = R \cdot I^2 \quad \rightarrow \quad I = \sqrt{\frac{P}{R}} = \sqrt{\frac{40 \text{ W}}{0.33 \text{ } \Omega}} \end{aligned}$$

$$\begin{aligned} R &= \rho \cdot \frac{l}{A} \quad | \quad \text{with } A = r^2 \cdot \pi = \frac{1}{4} d^2 \cdot \pi \quad || \quad R = \rho \cdot \frac{4 \cdot l}{d^2 \cdot \pi} \quad || \quad R = 1.10 \cdot 10^{-6} \text{ } \Omega \text{ m} \cdot \frac{4 \cdot 3 \text{ m}}{(3.57 \cdot 10^{-3} \text{ m})^2 \cdot \pi} \end{aligned}$$

**Exercise E2 Temperature-dependent Resistance**  
**(written test, approx. 6 % of a 60-minute written test, WS2022)**

2. A refrigerator, explains a thermodynamic process in a refrigeration system. The refrigerant has a resistance of  $10 \text{ k}\Omega$  at  $25^\circ\text{C}$ . Your answer.

Its temperature coefficients are:  $\alpha = 0.01 \text{ K}^{-1}$  and  $\beta = 71 \cdot 10^{-6} \text{ K}^{-2}$

Result: The temperature inside the refrigeration system can reach down to  $-40^\circ\text{C}$ .

Calculate the resistance of the thermistor at  $-40^\circ\text{C}$ .

The power transfer is  $P = U \cdot I$  and  $I = U/R$ . Therefore, a solution is to increase the resistance of the thermistor.

Therefore, with constant  $U$  and increasing  $R$  the power decreases. Ten times more resistance decreases the heat flow to one-tenth.

$$R = R_0 \cdot (1 + \alpha \cdot \Delta T + \beta \cdot \Delta T^2)$$

with  $\Delta T = T_{\text{end}} - T_{\text{start}}$

$$R = 10 \text{ k}\Omega \cdot \left(1 + 0.01 \text{ K}^{-1} \cdot (-40^\circ\text{C} - 25^\circ\text{C}) + 71 \cdot 10^{-6} \text{ K}^{-2} \cdot (-40^\circ\text{C} - 25^\circ\text{C})^2\right)$$

**Exercise E2 Temperature-dependent Resistance**  
**(written test, approx. 6 % of a 60-minute written test, WS2022)**

2. A refrigerator, explains a thermodynamic process in a refrigeration system. The refrigerant has a resistance of  $10 \text{ k}\Omega$  at  $25^\circ\text{C}$ . Your answer.

Its temperature coefficients are:  $\alpha = 0.01 \text{ K}^{-1}$  and  $\beta = 71 \cdot 10^{-6} \text{ K}^{-2}$

Result: The temperature inside the refrigeration system can reach down to  $-40^\circ\text{C}$ .

Calculate the resistance of the thermistor at  $-40^\circ\text{C}$ .

The power transfer is  $P = U \cdot I$  and  $I = U/R$ . Therefore, a solution is to increase the resistance of the thermistor.

Therefore, with constant  $U$  and increasing  $R$  the power decreases. Ten times more resistance decreases the heat flow to one-tenth.

$$R = R_0 \cdot (1 + \alpha \cdot \Delta T + \beta \cdot \Delta T^2)$$

with  $\Delta T = T_{\text{end}} - T_{\text{start}}$

$$R = 10 \text{ k}\Omega \cdot \left(1 + 0.01 \text{ K}^{-1} \cdot (-40^\circ\text{C} - 25^\circ\text{C}) + 71 \cdot 10^{-6} \text{ K}^{-2} \cdot (-40^\circ\text{C} - 25^\circ\text{C})^2\right)$$

**Exercise E3 Pure Resistor Network Simplification**  
**(written test, approx. 13 % of a 60-minute written test, WS2022)**

The following shall be solved at the end of the course. The result is given.  $R_B$ .

Solution

$$R_{\text{eq}} = 132.8 \, \Omega$$

Now a wye-delta transformation is necessary.



Since  $R_2 = R_3$  and based on the equations for the transformation, the transformed  $R_Y$  is given as:

$$R_Y = \frac{R_2 \cdot R_2}{R_2 + R_2 + R_2} = \frac{(100 \, \Omega)^2}{3 \cdot 100 \, \Omega} = \frac{1}{3} \cdot 100 \, \Omega = 33.33 \, \Omega$$

The equivalent resistor is given by a parallel configuration of resistors in series:

$$R_{\text{eq}} = R_Y + (R_Y + R_1 + R_1) \parallel (R_Y + R_2) \parallel R_4$$

.. The switch shall now be open. Calculate the equivalent resistance  $R_{\text{eq}}$  between terminals A and B.

Solution



The equivalent resistor is given by a parallel configuration of resistors in series:

$$R_{\text{eq}} = (R_2 + R_1 + R_1) \parallel (R_2 + R_2) \parallel R_{\text{eq}} = (100 \sim\Omega + 200 \sim\Omega + 200 \sim\Omega) \parallel (100 \sim\Omega + 100 \sim\Omega) \parallel R_{\text{eq}} = (500 \sim\Omega) \parallel (200 \sim\Omega) \parallel R_{\text{eq}} = \frac{500 \sim\Omega \cdot 200 \sim\Omega}{500 \sim\Omega + 200 \sim\Omega}$$

**Exercise E4 Pure Resistor Network Simplification**  
**(written test, approx. 13 % of a 60-minute written test, WS2022)**

The following shall be solved with  $R_1 = 200 \Omega$ ,  $R_2 = R_3 = 100 \Omega$  and the voltage source given.  $R_{\text{eq}}$  is given.

Solution

$$R_{\text{eq}} = 132.8 \Omega$$

Now a wye-delta transformation is necessary.



Since  $R_2=R_3$  and based on the equations for the transformation, the transformed  $R_Y$  is given as: 
$$R_Y = \frac{R_2 \cdot R_2}{R_2 + R_2 + R_2} = \frac{(100 \Omega)^2}{3 \cdot 100 \Omega} = \frac{1}{3} \cdot 100 \Omega = 33.33 \Omega$$

The equivalent resistor is given by a parallel configuration of resistors in series: 
$$R_{eq} = R_Y + (R_Y + R_1 + R_1) \parallel (R_Y + R_2) \parallel R_{eq} = 33.33 \Omega + (33.33 \Omega + 400 \Omega) \parallel (33.33 \Omega + 100 \Omega)$$

1. The switch shall now be open. Calculate the equivalent resistance  $R_{eq}$  between A and B.

Solution



The equivalent resistor is given by a parallel configuration of resistors in series:

$$R_{\text{eq}} = (R_2 + R_1 + R_{-1}) \parallel (R_2 + R_2) \parallel R_{\text{eq}} = (100 \Omega + 200 \Omega + 200 \Omega) \parallel (100 \Omega + 100 \Omega) \parallel R_{\text{eq}} = \{500 \Omega \parallel (200 \Omega) \parallel R_{\text{eq}} = \{500 \Omega \cdot 200 \Omega \over 500 \Omega + 200 \Omega\} \parallel$$

**Exercise E5 Equivalent linear Source  
(written test, approx. 14 % of a 60-minute written test, WS2022)**

The circuit in the following has to be simplified.  
Result

$$U_{\text{s}} = U_{\text{AB}} = 4.5 \text{ V} \quad R_{\text{i}} = R_{\text{AB}} = 6 \Omega$$



Calculate the internal resistance  $R_{int}$  and the source voltage  $U_{s}$  of an equivalent linear voltage source on the connectors  $A$  and  $B$ .  $R_1=5.0 \Omega$ ,  $U_2=6.0 \text{ V}$ ,  $R_3=10 \Omega$ ,  $I_4=4.2 \text{ A}$ ,  $R_5=10 \Omega$ ,  $R_6=7.5 \Omega$ ,  $R_7=15 \Omega$ . Use equivalent sources in order to simplify the circuit!

### Solution

The best thing is to re-think the wiring like rubber bands and adjust them:



The linear voltage source of  $U_2$  and  $R_1$  can be transformed into a current source  $I_2 = \frac{U_2}{R_1}$  and  $R_1$ :



Now a lot of them can be combined. The resistors  $R_1$ ,  $R_3$ ,  $R_5$  are in parallel, like also  $I_2$  and  $I_4$ :

$$R_{135} = R_1 || R_3 || R_5$$

$$I_{24} = I_2 - I_4 = \frac{U_{24}}{R_1} - I_4$$

The resulting circuit can again be transformed:



Here, the  $U_{24}$  is calculated by  $I_{24}$  as the following:

$$U_{24} = I_{24} \cdot R_{135} + I_4 \cdot R_1$$

$$U_{24} = U_2 \cdot \frac{R_7}{R_6 + R_7 + R_1 || R_3 || R_5} - I_4 \cdot R_1 || R_3 || R_5$$

On the right side of the last circuit, there is a voltage divider given by  $R_{135}$ ,  $R_6$ , and  $R_7$ .

Therefore the voltage between  $A$  and  $B$  is given as:

$$U_{AB} = U_{24} \cdot \frac{R_7}{R_6 + R_7 + R_1 || R_3 || R_5} - I_4 \cdot \frac{R_7 \cdot R_1 || R_3 || R_5}{R_6 + R_7 + R_1 || R_3 || R_5}$$

For the internal resistance  $R_i$  the ideal voltage source is substituted by its resistance ( $=0\Omega$ , so a short-circuit):

$$R_{AB} = R_7 || (R_6 + R_1 || R_3 || R_5)$$

with  $R_1 || R_3 || R_5 = 5\Omega || 10\Omega || 10\Omega = 5\Omega || 5\Omega = 2.5\Omega$ :

$$U_{AB} = \frac{6.0\text{V}}{5.0\Omega} - 4.2\Omega \cdot \frac{15\Omega \cdot 2.5\Omega}{7.5\Omega + 15\Omega + 2.5\Omega}$$

$$R_{AB} = 15\Omega || (7.5\Omega + 2.5\Omega)$$

### Exercise E6 Equivalent linear Source (written test, approx. 14 % of a 60-minute written test, WS2022)

The circuit in the following has to be simplified.  
Result

$$U_s = U_{AB} = 4.5\text{V} \quad R_i = R_{AB} = 6\Omega$$



Calculated the internal resistance  $R_{\text{int}}$  and the source voltage  $U_{\text{oc}}$  of an equivalent linear voltage source on the connectors  $\text{A}$  and  $\text{B}$ . 
$$R_1=5.0 \text{ } \Omega, \quad U_2=6.0 \text{ V}, \quad R_3= 10 \text{ } \Omega, \quad I_4=4.2 \text{ A}, \quad R_5=10 \text{ } \Omega, \quad R_6=7.5 \text{ } \Omega, \quad R_7=15 \text{ } \Omega$$
 Use equivalent sources in order to simplify the circuit!

Solution

The best thing is to re-think the wiring like rubber bands and adjust them:



The linear voltage source of  $U_2$  and  $R_1$  can be transformed into a current source  $I_2 = \frac{U_2}{R_1}$  and  $R_1$ :



Now a lot of them can be combined. The resistors  $R_1$ ,  $R_3$ ,  $R_5$  are in parallel, like also  $I_2$  and  $I_4$ : 
$$R_{135} = R_1 || R_3 || R_5$$
 
$$I_{24} = I_2 - I_4$$
 The resulting circuit can again be transformed:



Here, the  $U_{24}$  is calculated by  $I_{24}$  as the following: 
$$U_{24} = I_{24} \cdot R_{135}$$

$$U_{AB} = R_{135} \cdot I_{24} = \left( \frac{U_2}{R_1} - I_4 \right) \cdot R_1 \parallel R_3 \parallel R_5$$

On the right side of the last circuit, there is a voltage divider given by  $R_{135}$ ,  $R_6$ , and  $R_7$ .

Therefore the voltage between  $A$  and  $B$  is given as:

$$U_{AB} = U_{24} \cdot \left\{ \frac{R_7}{R_6 + R_7 + R_1 \parallel R_3 \parallel R_5} \right\} = \left( \frac{U_2}{R_1} - I_4 \right) \cdot \left\{ \frac{R_7 \cdot R_1 \parallel R_3 \parallel R_5}{R_6 + R_7 + R_1 \parallel R_3 \parallel R_5} \right\}$$

For the internal resistance  $R_i$  the ideal voltage source is substituted by its resistance ( $=0 \Omega$ , so a short-circuit):

$$R_{AB} = R_7 \parallel (R_6 + R_1 \parallel R_3 \parallel R_5)$$

with  $R_1 \parallel R_3 \parallel R_5 = 5 \Omega \parallel 10 \Omega \parallel 10 \Omega = 5 \Omega \parallel 5 \Omega = 2.5 \Omega$ :

$$U_{AB} = \left( \frac{6.0 \text{ V}}{5.0 \Omega} - 4.2 \text{ A} \right) \cdot \left\{ \frac{15 \Omega \cdot 2.5 \Omega}{7.5 \Omega + 15 \Omega + 2.5 \Omega} \right\}$$

$$R_{AB} = 15 \Omega \parallel (7.5 \Omega + 2.5 \Omega)$$

**Exercise E7 Charging Capacitors**  
(written test, approx. 16 % of a 60-minute written test, WS2022)

The circuit below is a battery with an internal resistance of  $R_1 = 5 \Omega$  and a charging capacitor  $C = 2 \mu\text{F}$  connected in parallel with an open switch. The voltage across the capacitor is again  $0 \text{ V}$  at the moment  $t_0 = 0 \text{ s}$  when the switch  $S_1$  is closed. Calculate the voltage  $u_c(t_2)$  across the capacitor at  $t_2 = 1 \text{ ms}$  after closing the switch.

**Solution:** To solve this, first create an equivalent linear voltage source from  $U$ ,  $R_1$ , and  $R_2$ .

$$U_{eq} = \frac{U \cdot R_2}{R_1 + R_2} = \frac{12 \text{ V} \cdot 2 \Omega}{5 \Omega + 2 \Omega} = 2 \text{ V}$$

On an alternative view, one can try to create an equivalent linear voltage source again. Then, the internal resistance is given by substituting the ideal voltage source is again short-circuiting  $R_2$ .



The circuit contains a voltage source  $U=12\text{ V}$ , a switch  $S_1$ , a resistor of  $R_1=20\text{ }\Omega$  and a capacitor of  $C=100\text{ }\mu\text{F}$ . The switch  $S_2$  to an additional consumer  $R_2$  will be considered to be open for the first task. At the moment  $t_0=0\text{ s}$  the switch  $S_1$  is closed, the voltage across the capacitor is  $u_c(t_0)=0\text{ V}$ .



First do not consider the light bulb - it is not connected to the RC circuit. Calculate the point of time  $t_1$  when  $u_c(t_1)=0.5 \cdot U$ .

Solution



So, here only  $R_1$  and  $C$  gives the time constant:  $\tau = R_1 \cdot C$

The following formula describes the time course of  $u_c(t)$  which has to be  $u_c(t_1)=0.5 \cdot U$ :  

$$u_c(t) = U \cdot (1 - e^{-t/\tau}) = 0.5 \cdot U$$
 It has to be rearranged to  $(1 - e^{-t/\tau}) = 0.5$ .  
 An equivalent linear voltage source can be given with  $U_s$ ,  $R_1$ , and  $R_B$  as seen in yellow:  

$$U_s = U \cdot \frac{R_B}{R_1 + R_B} = 1/2 \cdot U$$
 The internal resistance is given by substituting the ideal voltage source with its resistance ( $R_i = 0\text{ }\Omega$ , short-circuit):  

$$R_i = R_1 \parallel R_B = 10\text{ }\Omega$$

Therefore, the voltage of the equivalent linear voltage source is:  $U_s = U \cdot \frac{R_B}{R_1 + R_B} = 1/2 \cdot U$ . The internal resistance is given by substituting the ideal voltage source with its resistance ( $R_i = 0\text{ }\Omega$ , short-circuit).  

$$R_i = R_1 \parallel R_B = 10\text{ }\Omega$$
  

$$u_c(t_2) = U_s \cdot (1 - e^{-t_2/(R_i \cdot C)}) = \frac{1}{2} \cdot U \cdot (1 - e^{-1\text{ ms}/(10\text{ }\Omega \cdot 100\text{ }\mu\text{F})})$$

**Exercise E8 Charging Capacitors**  
 (written test, approx. 16 % of a 60-minute written test, WS2022)

The circuit (as shown in the figure) consists of a DC voltage source  $U=6\text{ V}$ , a resistor  $R_1=20\text{ }\Omega$ , a capacitor  $C=20\text{ }\mu\text{F}$ , and a light bulb  $R_B=10\text{ }\Omega$ . The switch  $S_1$  is open. At the moment  $t_0=0\text{ s}$  when the switch  $S_1$  is closed. Calculate the voltage  $u_c(t_2)$  across the capacitor at  $t_2=1\text{ ms}$  after closing the switch.

**Solution** To solve this, first create an equivalent linear voltage source from  $U$ ,  $R_1$ , and  $R_B$ .  

$$U_s = U \cdot \frac{R_B}{R_1 + R_B} = 2\text{ V}$$

$$R_i = R_1 \parallel R_B = 13.3\text{ }\Omega$$

Solution

The ideal voltage source is  $U = 12 \text{ V}$ . The internal resistance is  $R_1 = 20 \text{ }\Omega$ . The voltage across the capacitor is  $u_C$ . The voltage across the light bulb is  $u_B$ . The voltage across the resistor  $R_2$  is  $u_{R_2}$ . The voltage across the capacitor is  $u_C$ . The voltage across the light bulb is  $u_B$ . The voltage across the resistor  $R_2$  is  $u_{R_2}$ .

On an alternative view, one can try to create an equivalent linear voltage source again. Then, the internal resistance is given by substituting the ideal voltage source is again short-circuiting  $R_2$ .

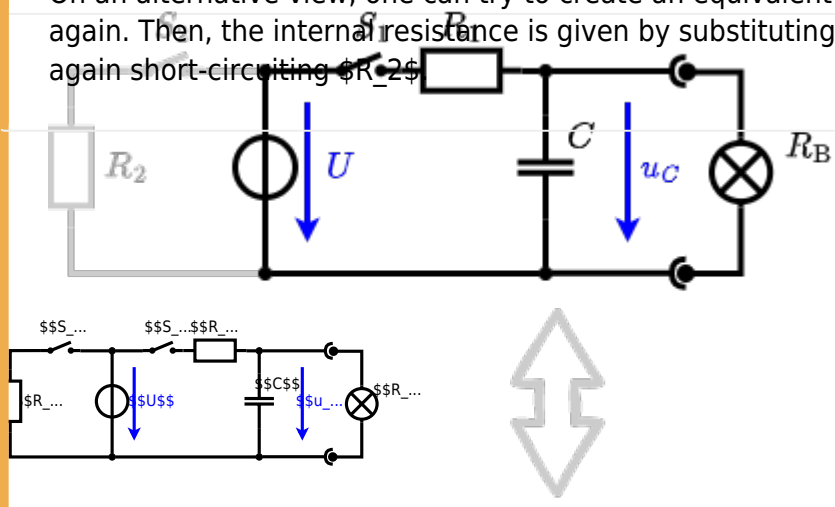

The circuit contains a voltage source  $U = 12 \text{ V}$ , a switch  $S_1$ , a resistor of  $R_1 = 20 \text{ }\Omega$  and a capacitor of  $C = 100 \text{ }\mu\text{F}$ .

The switch  $S_2$  to an additional consumer  $R_2$  will be considered to be open for the first asks. At the moment  $t_0 = 0$  the switch  $S_1$  is closed, the voltage across the capacitor is  $u_C(t_0) = 0$ .

First do not consider the light bulb - it is not connected to the RC circuit.

Calculate the point of time  $t_1$  when  $u_C(t_1) = 0.5 \cdot U$ .

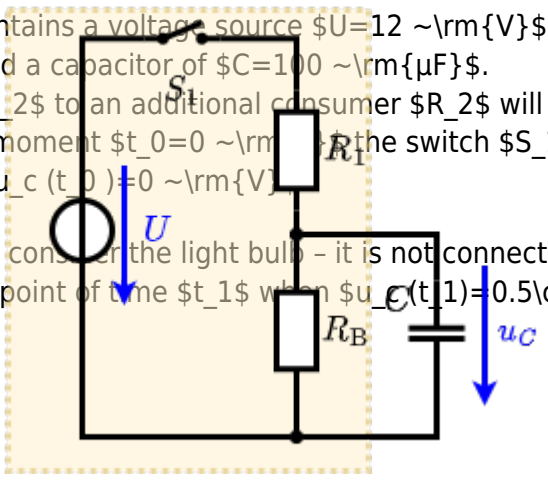

Solution

An equivalent linear voltage source can be given with  $U_s$ ,  $R_1$ , and  $R_B$  as seen in yellow.

Therefore, the voltage of the equivalent linear voltage source is:  $U_s = U \cdot \frac{R_B}{R_1 + R_B} = \frac{1}{2} \cdot U$ . The internal resistance is given by substituting the ideal voltage source with its resistance ( $R = 0 \text{ }\Omega$ , short-circuit).

$$R_i = R_1 \parallel R_B = 10 \text{ }\Omega$$

$$u_C(t_2) = U_s \cdot (1 - e^{-t_2 / (R_i \cdot C)}) = \frac{1}{2} \cdot U \cdot (1 - e^{-t_2 / (10 \text{ }\Omega \cdot 100 \text{ }\mu\text{F})})$$

So, here only  $R_1$  and  $C$  gives the time constant:  $\tau = R_1 \cdot C$

The following formula describes the time course of  $u_C(t)$  which has to be  $u_C(t_1) = 0.5 \cdot U$ :  $u_C(t) = U \cdot (1 - e^{-t/\tau}) = 0.5 \cdot U$ . It has to be rearranged to  $(1 - e^{-t/\tau}) = 0.5 \implies e^{-t/\tau} = 0.5 \implies t/\tau = \ln(0.5) \implies t = \tau \cdot \ln(0.5) = R_1 \cdot C \cdot \ln(0.5)$

### Exercise E9 Analyzing complex Impedances (written test, approx. 14 % of a 60-minute written test, WS2022)

2. Given that the phasor voltage  $\underline{u}(t) = 50 \cos(300t - 10^\circ)$  V and the phasor current  $\underline{i}(t) = 0.24 \cos(300t + \varphi)$  A are both through the components ( $R$  and  $X_L$ ) shall be given.

After analysis, the full bandwidth of the circuit impedance  $Z$  can be extracted and the phase angle  $\varphi$  in phase with the voltage  $\underline{u}(t) = 50 \cos(300t + \varphi)$  V shall be given.

Solution  
.. Calculation of the physical values of the two components.  
Solution 
$$R = 12.5 \Omega \quad X_L = 2.6 \Omega \quad \varphi = 87.06^\circ$$

Solution  
$$\underline{I} = \frac{\underline{U}}{\underline{Z}} \quad \varphi = 50^\circ$$
  
The current  $I$  and voltage  $U$  are in phase since  $\varphi = 0^\circ$  (pure real) resulting in  $I = 0.24 \cos(300t + \varphi)$  A and  $U = 50 \cos(300t - 10^\circ)$  V.  
Therefore, the component  $R$  is in phase with the voltage  $U$  and the impedance  $Z$  is  $\underline{Z} = R + jX_L = 12.5 + j2.6 \Omega$ .  
The phase angle  $\varphi$  can be calculated as  $\varphi = \arctan\left(\frac{X_L}{R}\right) = \arctan\left(\frac{2.6}{12.5}\right) = 11.7^\circ$ .  
The phase angle  $\varphi$  can be calculated as  $\varphi = \arctan\left(\frac{X_L}{R}\right) = \arctan\left(\frac{2.6}{12.5}\right) = 11.7^\circ$ .  
With the complex part  $Z = R + jX_L$  and  $\varphi = 11.7^\circ$ ,  
$$\varphi = \arctan\left(\frac{X_L}{R}\right) = \arctan\left(\frac{2.6}{12.5}\right) = 11.7^\circ$$

### Exercise E10 Analyzing complex Impedances (written test, approx. 14 % of a 60-minute written test, WS2022)

2. Given that the phasor voltage  $\underline{u}(t) = 50 \cos(300t - 10^\circ)$  V and the phasor current  $\underline{i}(t) = 0.24 \cos(300t + \varphi)$  A are both through the components ( $R$  and  $X_L$ ) shall be given.

After analysis, the full bandwidth of the circuit impedance  $Z$  can be extracted and the phase angle  $\varphi$  in phase with the voltage  $\underline{u}(t) = 50 \cos(300t + \varphi)$  V shall be given.

Solution  
.. Calculation of the physical values of the two components.  
Solution 
$$R = 12.5 \Omega \quad X_L = 2.6 \Omega \quad \varphi = 87.06^\circ$$

Solution  
$$\underline{I} = \frac{\underline{U}}{\underline{Z}} \quad \varphi = 50^\circ$$
  
The current  $I$  and voltage  $U$  are in phase since  $\varphi = 0^\circ$  (pure real) resulting in  $I = 0.24 \cos(300t + \varphi)$  A and  $U = 50 \cos(300t - 10^\circ)$  V.  
Therefore, the component  $R$  is in phase with the voltage  $U$  and the impedance  $Z$  is  $\underline{Z} = R + jX_L = 12.5 + j2.6 \Omega$ .  
The phase angle  $\varphi$  can be calculated as  $\varphi = \arctan\left(\frac{X_L}{R}\right) = \arctan\left(\frac{2.6}{12.5}\right) = 11.7^\circ$ .  
The phase angle  $\varphi$  can be calculated as  $\varphi = \arctan\left(\frac{X_L}{R}\right) = \arctan\left(\frac{2.6}{12.5}\right) = 11.7^\circ$ .  
With the complex part  $Z = R + jX_L$  and  $\varphi = 11.7^\circ$ ,  
$$\varphi = \arctan\left(\frac{X_L}{R}\right) = \arctan\left(\frac{2.6}{12.5}\right) = 11.7^\circ$$

The absolute value of the impedance is  $|Z| = \sqrt{R^2 + (X_L - X_C)^2}$  with  $R = 5 \Omega$ ,  $X_L = \omega L = 2\pi \cdot 4 \text{ MHz} \cdot 100 \text{ nH} = 2.51 \text{ m}\Omega$  and  $X_C = \frac{1}{\omega C} = \frac{1}{2\pi \cdot 4 \text{ MHz} \cdot 10 \text{ nF}} = 3.98 \text{ m}\Omega$ .  
 The phase  $\varphi$  is given by  $\varphi = \arctan\left(\frac{X_L - X_C}{R}\right) = \arctan\left(\frac{2.51 \text{ m}\Omega - 3.98 \text{ m}\Omega}{5 \Omega}\right) = -0.24 \text{ rad}$ .  
 With the complex part comes the physical value:  $I = \frac{U}{|Z|} = \frac{50 \text{ V}}{\sqrt{5^2 + (2.51 - 3.98)^2}} = 9.99 \text{ A}$ .  
 The phase  $\varphi$  is  $\varphi = -0.24 \text{ rad} = -13.7^\circ$ .

**Exercise E11 Impedances at different Frequencies**  
 (written test, approx. 18 % of a 60-minute written test, WS2022)

At a series circuit with  $R_1 = 100 \Omega$ ,  $R_2 = 470 \Omega$ ,  $L = 4.7 \mu\text{H}$  and  $C = 10 \text{ nF}$  at  $f = 4 \text{ MHz}$ , the absolute value of the impedance of the series circuit shall be the same as the absolute value of the impedance of a capacitor  $C_1 = 40 \text{ nF}$  at  $f_1 = 4 \text{ MHz}$ .

**Solution**

$R_1 = 100 \Omega$   
 $R_2 = 470 \Omega$

A series circuit means that the current is constant on every component.  
 The equivalent impedance for  $R_1$  and  $R_2$  combined is given by  $R_{12} = R_1 + R_2 = 570 \Omega$ .  
 Parallel circuit means that the voltage is the same on  $R_3$  and  $C_1$ .  
 The equivalent impedance for  $R_3$  and  $C_1$  combined is given by  $Z_{3C} = \frac{R_3 \cdot X_{C1}}{R_3 + X_{C1}}$ .  
 Since  $X_{C1} = \frac{1}{\omega C_1} = \frac{1}{2\pi \cdot 4 \text{ MHz} \cdot 40 \text{ nF}} = 9.95 \text{ m}\Omega$  is perpendicular to  $R_3 = 100 \Omega$ , this can be simplified to  $Z_{3C} = \frac{R_3 \cdot X_{C1}}{R_3}$ .  
 The resulting current of the parallel circuit is given as:  
 $I_{3C} = \frac{U}{Z_{3C}} = \frac{U}{R_3} = \frac{50 \text{ V}}{100 \Omega} = 0.5 \text{ A}$ .  
 This current has to be the same as the current through  $R_{12}$ .  
 $I_{3C} = I_{12} = \frac{U}{Z_{12C}} = \frac{50 \text{ V}}{\sqrt{R_{12}^2 + Z_{3C}^2}} = 0.5 \text{ A}$   
 $\sqrt{570^2 + Z_{3C}^2} = \frac{50 \text{ V}}{0.5 \text{ A}} = 100 \Omega$   
 $Z_{3C} = \sqrt{100^2 - 570^2}$  (This is not possible, so there is a mistake in the original text.)

**Exercise E12 Impedances at different Frequencies**  
 (written test, approx. 18 % of a 60-minute written test, WS2022)



□□□□□□□□□□ 10510...









From:  
<https://first.mexle.te.hs-heilbronn.de/> - **MEXLE Wiki**

Permanent link:  
[https://first.mexle.te.hs-heilbronn.de/electrical\\_engineering\\_1/ws2022\\_exam?rev=1680387138](https://first.mexle.te.hs-heilbronn.de/electrical_engineering_1/ws2022_exam?rev=1680387138)

Last update: **2023/04/02 00:12**

